

ALL URETHANE

FILMING PIGS - solid cast

3-12" (76-305mm)

A new addition to our world class line of pipeline products, the new design can be counted on to perform up to Apache Pipeline Products high standards to optimize the maintenance of your pipeline.

The unique design of our new dual durometer Hurricane FP pig has a front hollow mandrel with two port holes in the middle of the mandrel. This allows the inhibitor to travel to the front of the pig and then through the port holes. The inhibitor is then contained between the 86 durometer (hard) leading cup and two 62 durometer (soft) rear sealing discs allowing the pig to leave a film of inhibitor on the pipe wall. **Designed to traverse 1.5D bends.**

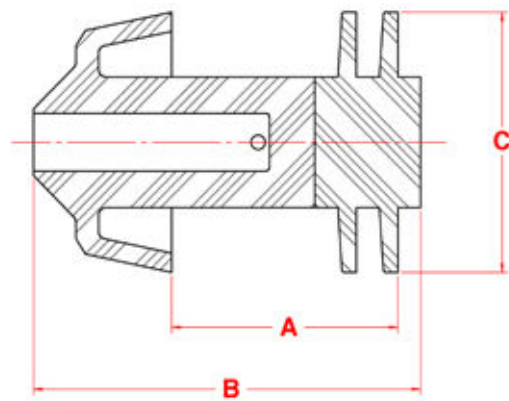
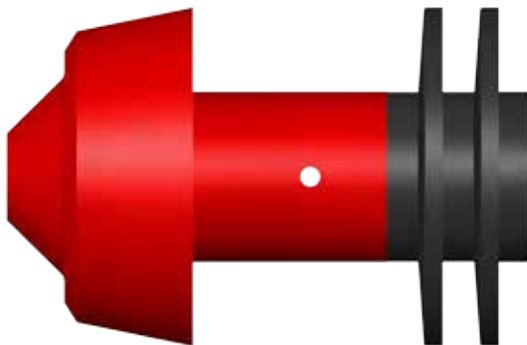

Size	A	B	C	Weight	Part #
3"	2.500	4.875	3.375	1.0	74-0462-03
4"	3.625	6.250	4.375	2.0	74-0462-04
6"	5.375	8.750	6.500	4.0	74-0462-06
8"	7.625	11.750	8.500	10	74-0462-08
10"	9.625	14.125	10.625	20	74-0462-10
12"	10.125	15.375	12.500	32	74-0462-12



Check out apachepipe.com/animations.html for videos on filming pigs.

AVAILABLE AT OUR
U.S. DISTRIBUTOR

